

## RIGID-MOUNT WASHER EXTRACTOR

**MWCL25 - MWCL30 - MWCL40**  
**G FORCE = 200 | 11 - 14 - 18 kg**



### CHARACTERISTICS

- **G Force = 200.**
  - Hard-mounted machines. Require anchoring to the floor.
  - Drum and jacket in AISI-304 stainless steel.
  - Unit exterior manufactured in sandwich board, colour grey, stainless steel appearance, easy to clean, and which does not reflect fingerprints.
  - Detergent tray with 4 compartments.
  - 8 signals for automatic liquid dosing, programmable in time and delay. 6 extra signals available optionally.
  - 3 standard water inlets.
  - Variable-frequency drive (standard 50-60 Hz). Balancing systems controlled by the same drive.
  - **New second-generation TOUCH PLUS programmer**
  - Allows programming, importing and exporting of programs and software updates via USB.
  - Traceability as standard: the whole wash process (temperatures, water levels) is stored on the washer and is extractable to a PC by USB memory.
  - The programmer includes the characteristics to create any Wet Cleaning program (modifiable water levels and washing speed).
  - **EFFICIENT MIX.** These machines are equipped with an automatic water mixer (mixing different water temperatures) which provides energy savings and reduces washing times.
  - **BALANCE CONTROL.** Thanks to an advanced technological development, and by means of the inverter, the washers detect the imbalance at an early stage. This way the operation is much smoother, elongating components lifetime and reducing washing times, thus saving energy as well.
  - **MULTICHOICE INLET.** All washers are equipped with a third water inlet as standard, which allows you to save filling time, or which can be used for decalcified water, ozone or recycled water.
  - **WET CLEANING.** All washers incorporate the necessary features to use the WET CLEANING system as standard, avoiding investment in expensive applications to work with this advanced washing concept. This feature replaces most dry-cleaning washing systems, bringing maximum reduction in costs.
  - **MAINTENANCE KARE.** A simple and reliable design with easy-to-access mechanical parts that combines perfectly with the use of intelligent electronics. All components have been designed and manufactured with top quality and prestige, focusing on optimum accessibility for all points and components key to maintenance. Moreover, all the controls have been developed down to the finest detail: complete technical menus, fault self-diagnosis systems, alarms, restricted access areas, etc.
  - **OPTIMISED DRUM.** This system has been developed to improve wash quality to the maximum and to do it in as short a time as possible. Through a series of perforations in the paddles of the drum, a water cascade effect is achieved which considerably increases the mechanical action inside the drum during operation and greatly reduces the amount of water needed for each wash. The effective design of the drum and tank with minimal spaces between them, allows the energy consumption necessary to heat the water, as well as the superfluous use of chemical products, to be reduced.
  - **OPTIMAL CONSUMPTION.** All washers are equipped with an efficient system by means of which you can indicate the load which is introduced in the machine. The washer automatically adapts the quantity of water and chemicals to be used for that load.
  - **"LOADING AID" system.** Water inlet and spin control for loading the linen.
  - The standard model can be converted to self-service by installing a pay station kit, coin mechanism kit or other payment system. RS-485 communication.
  - Washers compatible with water recovery tanks.
  - **CE, WRAS and EAC product certifications.** Optional ETL-certified version of the machine.
- OPTIONS:
- Anchoring base as an option for correct fixation to the floor.
  - Unit exterior in AISI-304 stainless steel.
  - Front panels in AISI-304 stainless steel.
  - Double drain kit to recover the water, with important savings.
  - NC Option: drain normally closed.
  - Reversible door opening.
  - Silicone seal for 11 and 14 kg models.
  - 6 extra signals for dosing
  - Timed opening system.
  - Printer.
  - Shower system: water recirculation for very delicate linen (wet cleaning complement).
  - Marine electric versions for ships.
  - Tropicalised models with protective covering for the electronics system.
  - SLUICE option. Essential for wash processes of sheets and other fabrics with solid contamination. Ø 8 mm perforations in the drum which facilitate the outlet of solid waste.

## TECHNICAL DATA

	UNIT.	MWCL-25	MWCL-30	MWCL-40			
<b>DRUM</b>							
Load capacity	lb/kg	25/11	30/14	40/18			
Volume	Lit	100	130	180			
Diameter	mm	620	620	700			
Depth	mm	330	430	470			
<b>GENERAL DATA</b>							
Wash speed / Spin speed	r.p.m.	53/759	53/759	50/714			
G Force	-	200	200	200			
Maximum force transmitted	kN	2.0 ±3	2.31 ±4	2.63 ±5			
Dynamic force frequency	Hz	8.93	8.93	8.42			
Noise level	dB	< 70	< 70	< 70			
Self-service version	-	Yes	Yes	Yes			
Double drain	-	No	Opt.	Opt.			
Weighing system	-	No	No	No			
SLUICE option	-	Yes	Yes	Yes			
<b>DOOR</b>							
Height door centre / Height door base	mm	570/310	570/310	655 / 348			
Diameter	mm	373	373	460			
<b>POWER</b>							
Motor	kW	1.1	1.1	2.2			
Heating electric mod.	kW	6	9	12			
Maximum electrical power	kW	6.25	9.5	12.75			
Maximum steam and hot water power	kW	1.1	1.1	2.2			
<b>CONNECTIONS</b>							
		<b>ELECTRIC</b>	<b>STEAM / HOT WATER</b>	<b>ELECTRIC</b>	<b>STEAM / HOT WATER</b>	<b>ELECTRIC</b>	<b>STEAM / HOT WATER</b>
Voltage 230V - I + N	Nº x mm² / A	3 x 6 / 40 A	3 x 1.5 / 16 A	3 x 10 / 50 A	3 x 1.5 / 16 A	3 x 16 / 63 A	3 x 4 / 32 A
Voltage 230V - III	Nº x mm² / A	4 x 2.5 / 20 A	-	4 x 2.5 / 20 A	-	4 x 6 / 40 A	-
Voltage 400V - III + N	Nº x mm² / A	5 x 1.5 / 16 A	-	5 x 1.5 / 16 A	-	5 x 4 / 32 A	-
Steam inlet (Steam mod.)	inch	1/2"		1/2"		1/2"	
Maximum steam consumption (Steam. mod.)	kg/h	7		8.5		12	
Water inlet	inch	3/4"		3/4"		3/4"	
Grid pressure	kg/cm²	2-4		2-4		2-4	
Maximum water consumption *	Lit/h	61.5*		78.8*		120*	
Drain	mm/inch	3"		3"		3"	
Drainage capacity	Lit/min	200		200		200	
<b>DIMENSIONS / DIMENSIONS WITH PACKAGING</b>							
Width / Width	mm	719 / 800		719 / 800		788 / 840	
Depth / Depth	mm	684 / 990		830 / 990		840 / 1,010	
Height / Height	mm	1,158 / 1,350		1,158 / 1,350		1,307 / 1,500	
Net weight / Gross weight	kg	217 / 225		239 / 247		281 / 301	
Gross volume (with packaging)	m³	1.07		1.07		1.3	

\* Program n° 20, 75 % load.

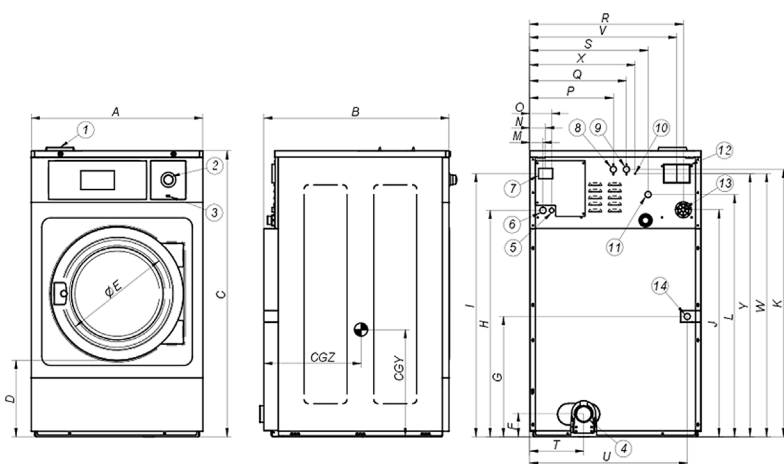

- ① Soap dispenser.
- ② Emergency stop.
- ③ USB port.
- ④ Drain.
- ⑤ Electrical connection to liquid soap pumps.
- ⑥ Electrical connection.
- ⑦ Main switch.
- ⑧ Auxiliary water inlet.
- ⑨ Hot water inlet.
- ⑩ Earth connection.
- ⑪ Cold water inlet.
- ⑫ Water overflow.
- ⑬ Connection for liquid soap.
- ⑭ Steam connection.

	A	B	C	D	E	F	G	H	I	J	K	L	M	N	O	P	Q	R	S	T	U	V	W	X	Y	CGY	CGZ
MWCL-25	719	684	1,158	310	373	144	440	886	1,054	889	1,073	958	61	74	101	316	376	637	475	211	654	607	1,073	424	1,118	383	511
MWCL-35	719	830	1,158	310	373	144	440	886	1,054	889	1,073	958	61	74	101	316	376	637	475	211	654	607	1,073	424	1,118	484	524
MWCL-40	788	840	1,307	348	460	108	552	1,035	1,203	1,038	1,222	1,107	61	74	101	385	445	706	544	249	724	676	1,203	485	1,202	479	546